

DESPIECE TECNICO
LISTE DE PIÈCES DÉTACHÉES
SPARE PARTS LIST

Octubre - 1995

COCINAS ELECTRICAS
FOURNEAUX ELECTRIQUES
ELECTRICAL RANGES

Modelos:

CE-920

CE-940

CE-941



Proyectos e Instalaciones y S.A.T.
Oñati, 24 de Enero de 1996

Hostelería, Frío Comercial y Lavandería Industrial
Grandes Cuisines, Froid Commercial et Buanderie
Catering, Commercial Refrigeration and Laundry Equipment

Fagor Industrial, S. Coop.
20560 - Oñati - España



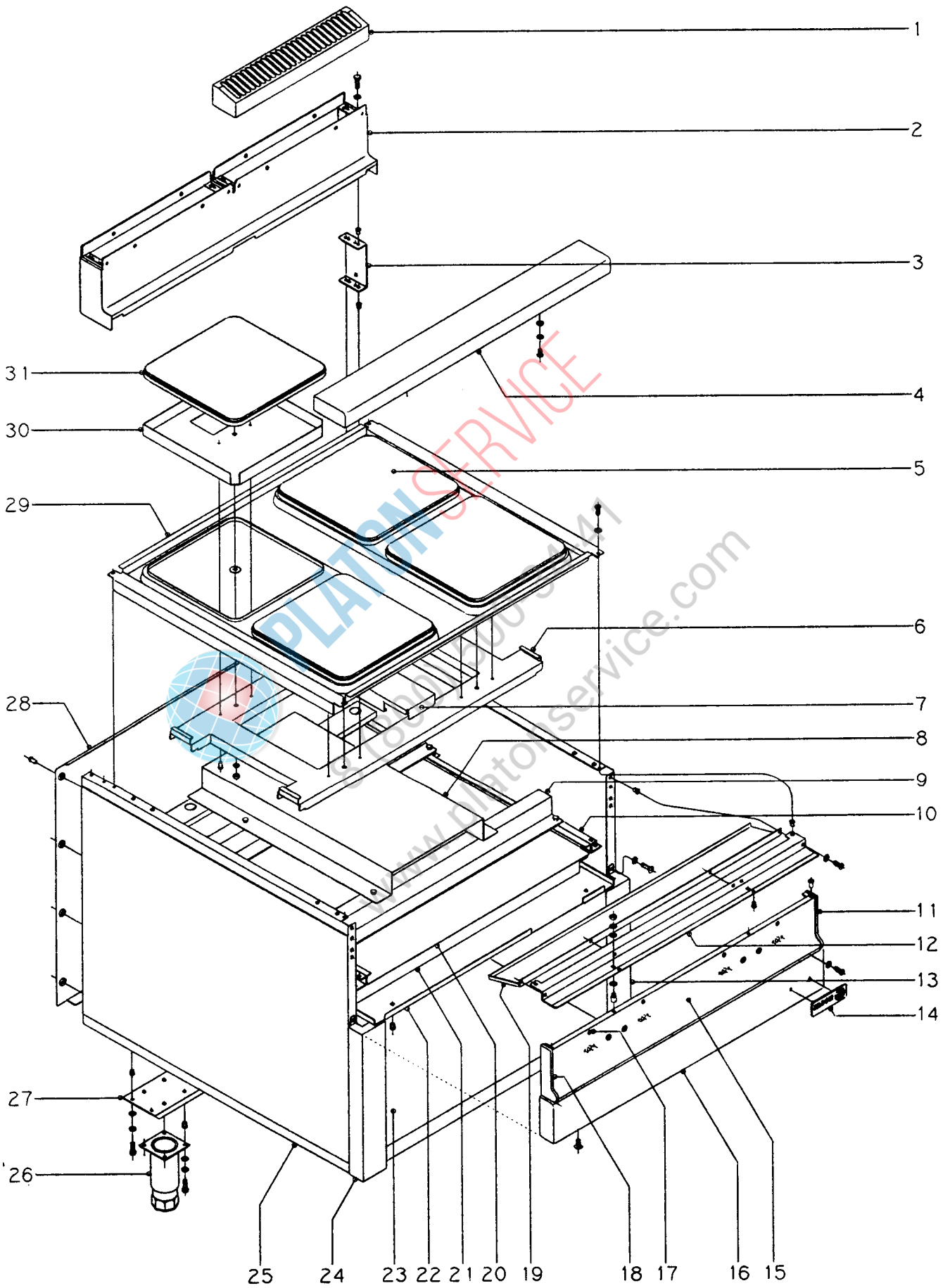

N plano C-297	Firma 	Fecha X-95	Aparato COCINAS CE-920 : CE-940	Lamina 1	Fagor Industrial S.Coop. FAGOR Orate
------------------	-----------	---------------	------------------------------------	-------------	--

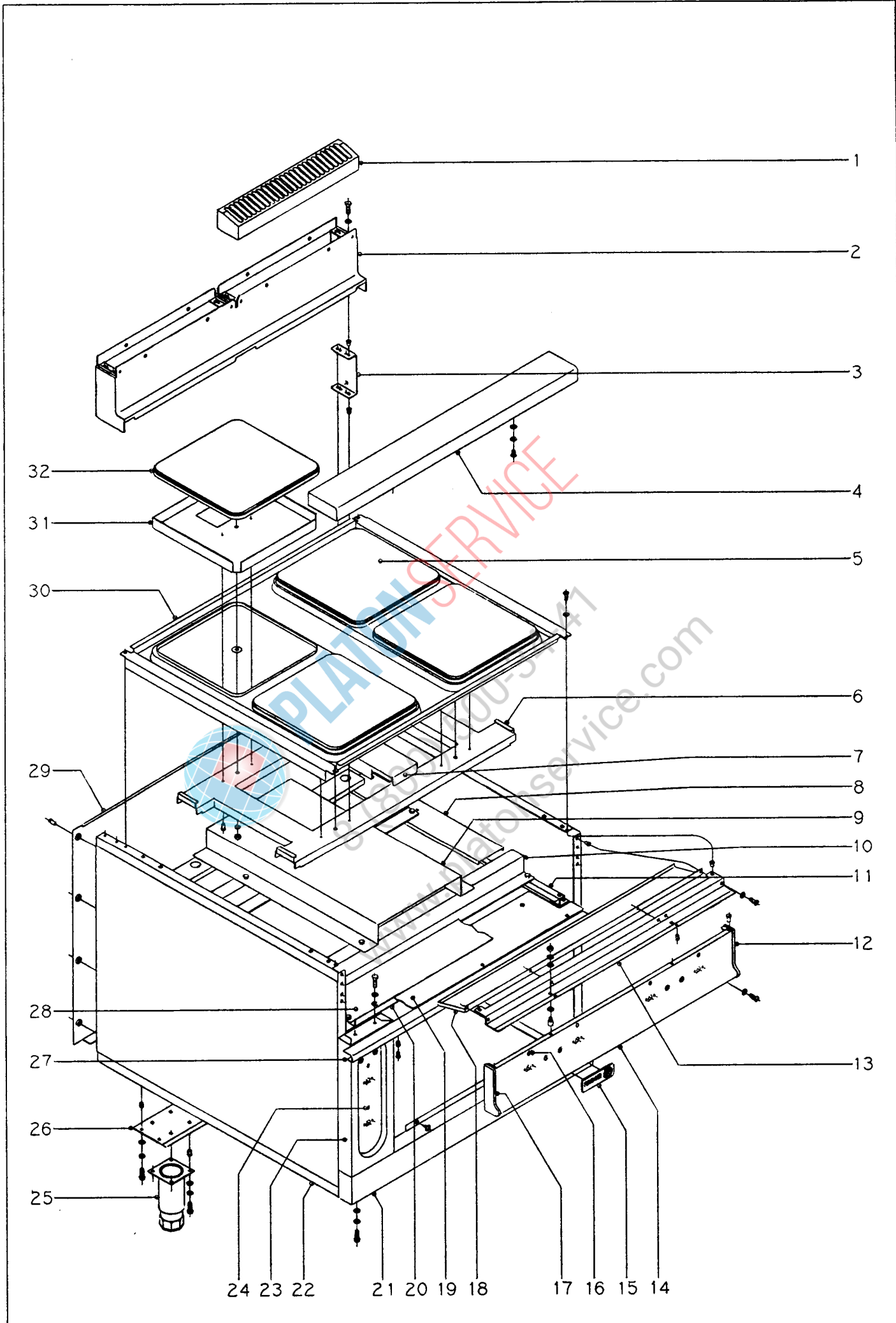

CONCEPTO: MUEBLE EXTERIOR SUJET: MEUBLE EXTERIEUR CONCEPT: EXTERNAL CABINET					LAMINAN° VUE N° ILUSTR. N.		PLANON° PLAN N° DRAWINGN.		PAGINAN° PAGE N° PAGEN.	
					1		C-297		4	
APARATO - APPAREIL - APPLIANCE: Cocinas - Fourneaux - Ranges					MODELO Y CANTIDAD - MOD. ET QUANT. - MOD. & QUANT.					OBSERVACIONES
N°	CODIGO	DENOMINACION	DENOMINATION	DESCRIPTION	CE-920	CE-940				
16	R212802	Panel anterior inferior 1/2 M.	Panneau antérieur inférieur	Lower front panel	1	-				
16	R222802	Panel anterior inferior 1 M.	Panneau antérieur inférieur	Lower front panel	-	1				
	Q221343	Remache exagonal M.6	Rivet M.6	Rivet M.6	2	2				
	Q151105	Tornillo amarre M.6x13	Vis M.6x13	Bolt M.6x13	2	2				
17	U562805	Indicador de quemadores	Indicateur de brûleurs	Burner indicator	2	4				
	Q221026	Clips sujeción indicador	Clip fixation	Quick fastening clip	2	4				
18	U262810	Cantонера izquierda portamandos	Cantonière gauche	Control panel curb bar-left	1	1				
	Q419005	Remache tubular 4x8	Rivet 4x8	Rivet 4x8	2	2				
19	U652602	Caja recoge-aguas	Boîte ramasse-eau	Water collector	1	-				
19	U672611	Caja recoge-aguas	Boîte ramasse-eau	Water collector	-	1				
20	U562642	Base de bandejas	Base plaque de four	Tray base	-	1				
	Q011431	Tornillo exagonal M.5x10	Vis M.5x10	Bolt M.5x10	-	4				
	Q242030	Arandela abanico A.5	Rondelle A.5	Washer A.5	-	4				
	Q221342	Remache exagonal M.5	Rivet M.5	Rivet M.5	-	4				
21	U552600	Soporte base de bandejas	Support base de plateaux	Support of tray base		2				
	Q011431	Tornillo exagonal M.5x10	Vis M.5x10	Bolt M.5x10		2				
	Q242030	Arandela abanico A.5	Rondelle A.5	Washer A.5	-	2				
	Q221342	Remache exagonal M.5	Rivet M.5	Rivet M.5	-	2				
22	U542801	Panel superior interior	Panneau supérieur intérieur	Upper lower panel	1	-				
22	U552801	Panel superior interior	Panneau supérieur intérieur	Upper lower panel	-	1				
	Q221343	Remache exagonal M.6	Rivet M.6	Rivet M.6	4	4				
	Q242040	Arandela abanico A.6	Rondelle A.6	Washer A.6	4	4				
	Q011342	Tornillo exagonal M.6x15	Vis M.6x15	Bolt M.6x15	4	4				
23	R210301	Base inferior 1/2 M.	Base inférieur	Lower base	1	-				
23	R200303	Base inferior 1 M.	Base inférieur	Lower base	-	1				
	Q221342	Remache exagonal M.5	Rivet M.5	Rivet M.5	6	6				
	Q242030	Arandela abanico A.5	Rondelle A.5	Washer A.5	6	6				
	Q011331	Tornillo exagonal M.5x10	Vis M.5x10	Bolt M.5x10	6	6				
24	R200300	Panel lateral izquierdo interior	Panneau latéral gauche inter.	Interior left side panel	1	1				
	Q242030	Arandela abanico A.5	Rondelle A.5	Washer A.5	1	1				
	Q152004	Tornillo aplastado M.5x10	Vis M.5x10	Bolt M.5x10	1	1				

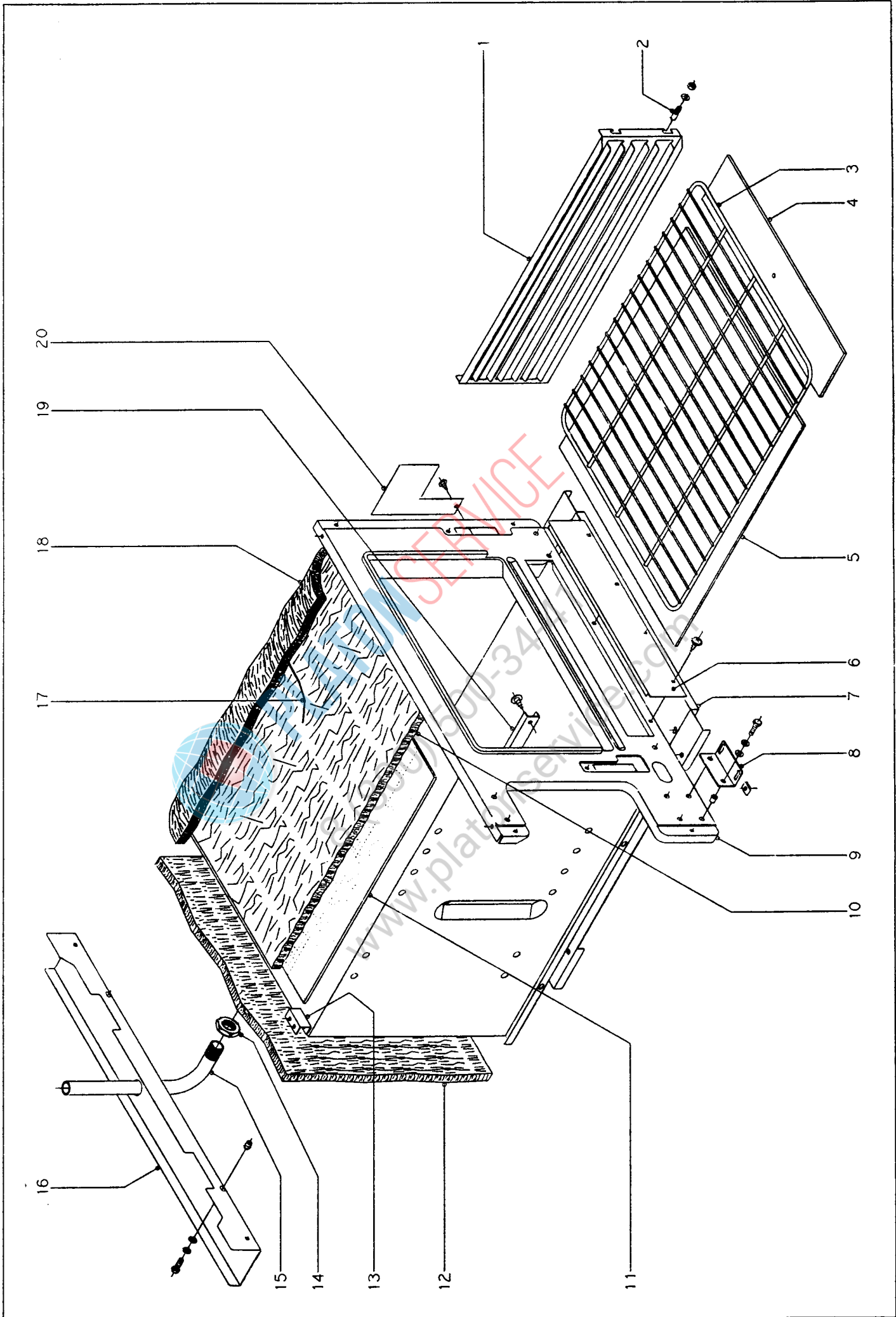

N plano C-298	Firma 	Fecha X-95	Aparato COCINA CE-941	Lámina 2	Fagor Industrial S.Coop. FAGOR Date
------------------	--	---------------	--------------------------	-------------	---

CONCEPTO: MUEBLE EXTERIOR SUJET: MEUBLE EXTERIEUR CONCEPT: EXTERNAL CABINET					LAMINAN° VUE N° 2 ILUSTR. N.		PLANON° PLAN N° C-298 DRAWINGN.		PAGINAN° PAGEN° 8 PAGEN.	
APARATO - APPAREIL - APPLIANCE: Cocinas - Fourneaux - Ranges					MODELO Y CANTIDAD - MOD. ET QUANT. - MOD. & QUANT.					OBSERVACIONES
N°	CODIGO	DENOMINACION	DENOMINATION	DESCRIPTION	CE-941					
10	U672610	Soporte refuerzo mesa	Support de table	Table frame	2					
	Q012031	Tornillo exagonal M.5x10	Vis M.5x10	Bolt M.5x10	4					
	Q261030	Arandela muelle A.5	Rondelle A.5	Washer A.5	4					
	Q302022	Arandela plana 16x6x1,2	Rondelle 16x6x1,2	Washer 16x6x1,2	4					
	Q222011	Remache exagonal M.5	Rivet M.5	Rivet M.5	4					
11	U562603	Amarre base de bandejas	Support inferieur plateaux	Trays lower support	4					
	Q419005	Remache tubular 4x8	Rivet 4x8	Rivet 4x8	8					
12	U262809	Cantonera derecha portamandos	Cantonière droite	Control panel curb bar-right	1					
	Q419005	Remache tubular 4x8	Rivet 4x8	Rivet 4x8	2					
13	R202601	Escuadra fijación portamandos	Equerre de fixation	Fastening plate	1					
	Q221342	Remache exagonal M.5	Rivet M.5	Rivet M.5	4					
	Q242030	Arandela abanico A.5	Rondelle A.5	Washer A.5	4					
	Q152004	Tornillo aplastado M.5x10	Vis M.5x10	Bolt M.5x10	4					
	Q151336	Tornillo soporte guía portaman.	Vis	Bolt	2					
	Q302022	Arandela plana 16x6x1,2	Rondelle 16x6x1,2	Washer 16x6x1,2	4					
	Q242040	Arandela abanico A.6	Rondelle A.6	Washer A.6	2					
	Q161440	Tuerca exagonal M.6	Ecrou M.6	Nut M.6	2					
14	U672800	Panel portamandos	Panneau-commandes	Control panel	1					
	Q221342	Remache exagonal M.5	Rivet M.5	Rivet M.5	2					
	Q242030	Arandela abanico A.5	Rondelle A.5	Washer A.5	2					
	Q152004	Tornillo aplastado M.5x10	Vis M.5x10	Bolt M.5x10	2					
15	R202899	Escudo FAGOR	Emblème FAGOR	FAGOR emblem	1					
	Q221023	Clips sujeción escudo	Clip fixation	Quick fastening clip	2					
16	U562805	Indicador de quemadores	Indicateur de brûleurs	Indicator	4					
	Q221026	Clips sujeción indicador	Clip fixation	Quick fastening clip	4					
17	U262810	Cantonera izquierda portamandos	Cantonière gauche	Control panel curb bar-left	1					
	Q419005	Remache tubular 4x8	Rivet 4x8	Rivet 4x8	2					
18	U672611	Caja recoge-aguas	Boîte ramasse eaux	Water colector	1					
19	U672612	Protección horno inferior	Protection inferieur du four	Oven lower protection	1					
	Q419005	Remache tubular 4x8	Rivet 4x8	Rivet 4x8	4					



N plano C-299	Firma 	Fecha X-95	Aparato COCINA CE-941	Lamina 3	Fagor Industrial S.Coop. FAGOR  Onate
------------------	--	---------------	--------------------------	-------------	--

CONCEPTO: HORNO SUJET: FOUR CONCEPT: OVEN					LAMINAN° VUE N° ILUSTR. N.	3	PLANON° PLAN N° DRAWINGN.	C-299	PAGINAN° PAGEN° PAGEN.	12
APARATO - APPAREIL - APPLIANCE: Cocinas - Fourneaux - Ranges					MODELO Y CANTIDAD - MOD. ET QUANT. - MOD. & QUANT.					OBSERVACIONES
N°	CODIGO	DENOMINACION	DENOMINATION	DESCRIPTION	CE-941					
1	U325608	Guía de bandejas	Glissière pour plaques de four	Oven tray guide	2					
2	Q151336	Tornillo soporte guías	Vis support glissières	Guide support screw	8					
	Q302022	Arandela plana 16x6x1,2	Rondelle 16x6x1,2	Washer 16x6x1,2	16					
	Q162040	Tuerca exagonal M.6	Ecrou M.6	Nut M.6	8					
3	U135635	Parrilla de horno	Grille du four	Oven grill	1					
4	U265630	Cabeza placa de horno	Complement pour plaque du four	Supplement plate	1					
5	U265631	Placa de horno	Plaque du four	Oven plate	1					
6	U672616	Cubierta frontal horno	Couvercle frontal du four	Oven front cover	1					
	Q151401	Tornillo alomado	Vis	Bolt	2					
7	U672600	Base de horno	Base de four	Oven base	1					
	Q221343	Remache exagonal M.6	Rivet M.6	Rivet M.6	4					
	Q012042	Tornillo exagonal M.6x15	Vis M.6x15	Bolt M.6x15	4					
	Q162040	Tuerca exagonal M.6	Ecrou M.6	Nut M.6	2					
	Q262040	Arandela muelle A.6	Rondelle A.6	Washer A.6	4					
	Q302022	Arandela plana 16x6x1,2	Rondelle 16x6x1,2	Washer 16x6x1,2	4					
8	U562803	Escuadra amarre paneles	Equerre fixation de panneaux	Fastening plate	3					
	Q221321	Remache roscado M.6	Rivet M.6	Rivet M.6	6					
	Q302022	Arandela plana 16x6x1,2	Rondelle 16x6x1,2	Washer 16x6x1,2	6					
	Q242040	Arandela abanico A.6	Rondelle A.6	Washer A.6	6					
	Q012042	Tornillo exagonal M.6x15	Vis M.6x15	Bolt M.6x15	6					
9	U675600	Horno	Four	Oven	1					
10	U675605	Aislante superior vitrofib	Isolant superieur	Roof insulant	1					
11	U675604	Aislante superior barlan	Isolant paroi sup. (barlan)	Roof insulant (barlan)	1					
12	U265617	Aislante posterior vitrofib	Isolant arrière de four	Rear oven insulant	1					
13	U565600	Fijación horno a base bandejas	Plaque de fixation	Fastening plate	2					
	Q221342	Remache exagonal M.5	Rivet M.5	Rivet M.5	8					
	Q232030	Arandela plana A.5	Rondelle A.5	Washer A.5	8					
	Q012032	Tornillo exagonal M.5x15	Vis M.5x15	Bolt M.5x15	8					
14	Q221324	Tuerca exagonal 3/4"	Ecrou 3/4"	Nut 3/4"	2					
15	U675606	Tubo extractor vapores	Conduite extraction fumées	Steam extraction pipe	1					

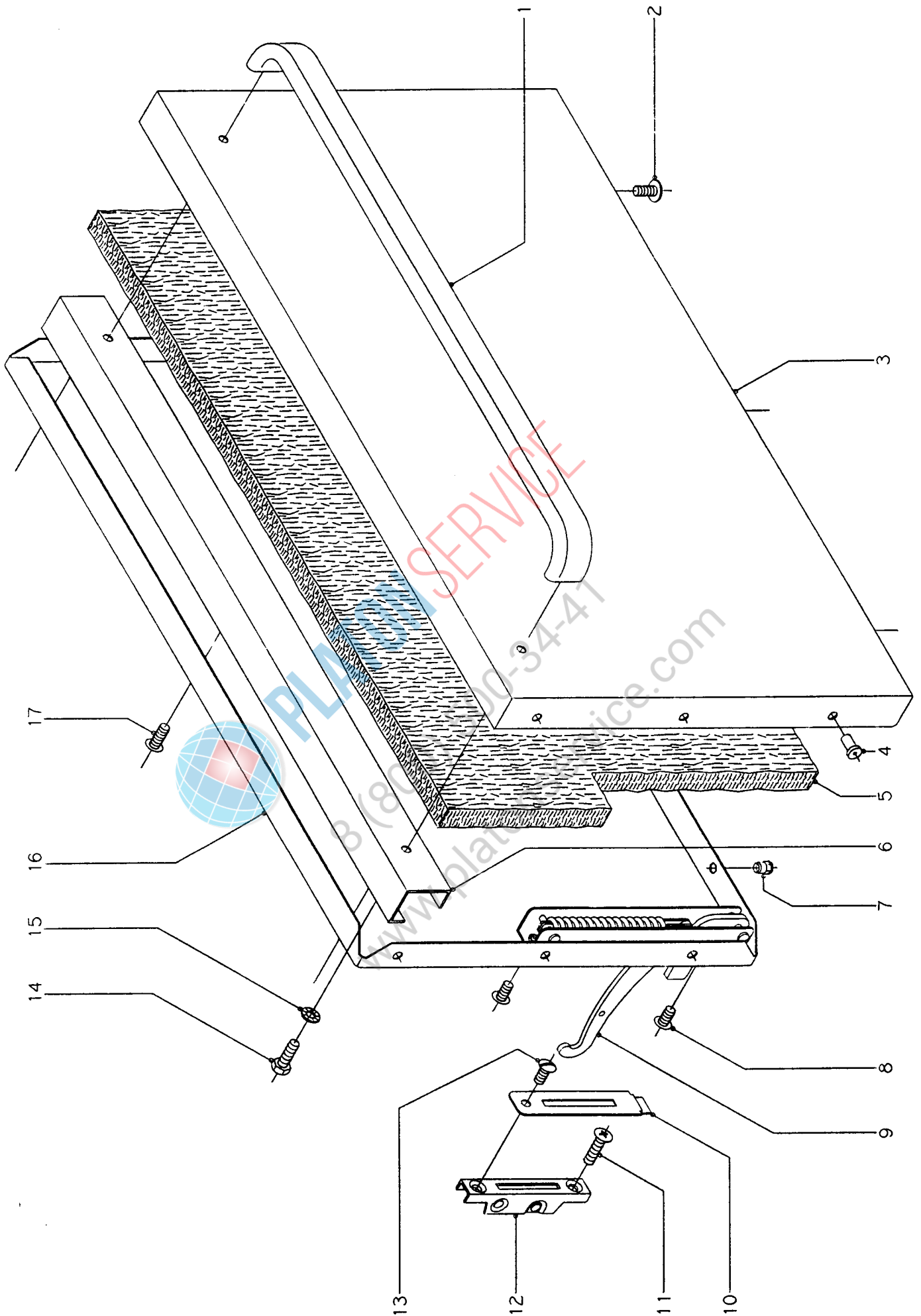

N plano
C-300

Firma

Fecha
X-95

Aparato

COCINA CE-941

Lamina
4

Fagor Industrial S.Coop. **FAGOR**
Ofite

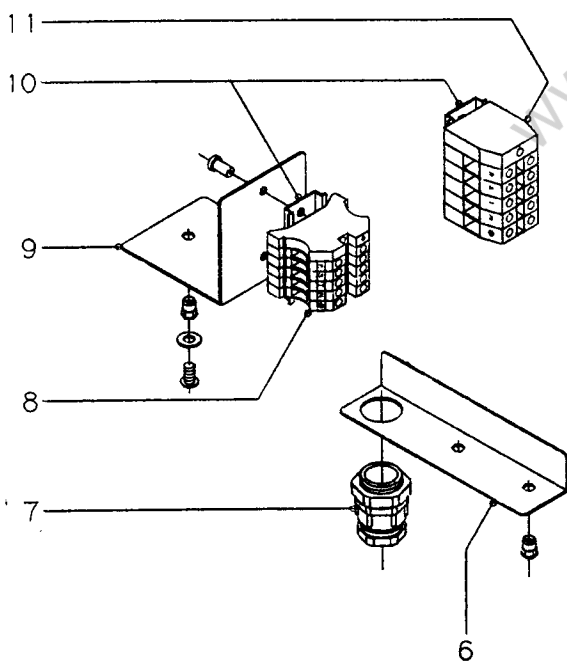
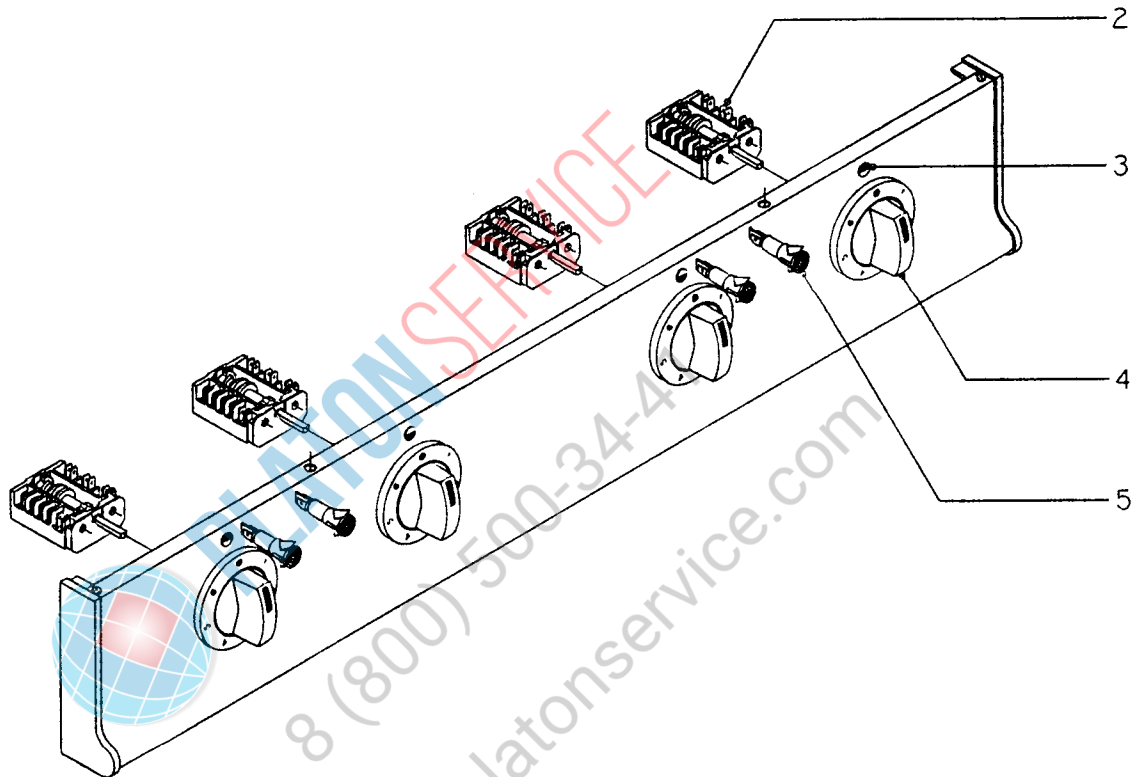
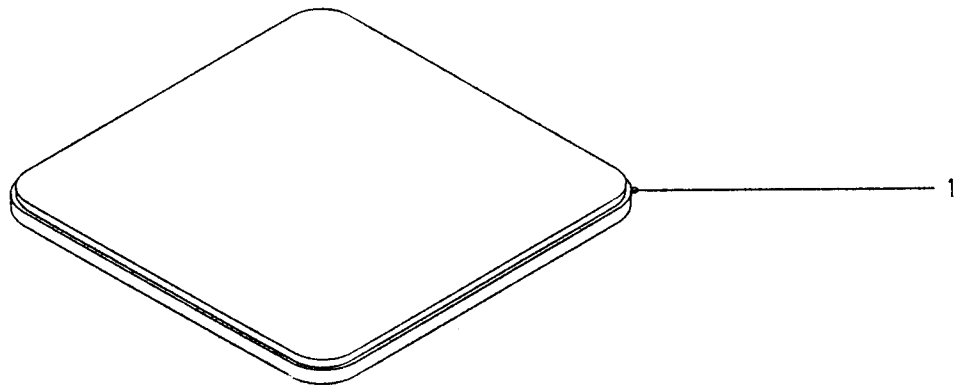

8 (800) 500-34-4
www.platonservice.com

N plano C-301	Firma 	Fecha X-95	Aparato COCINAS CE-920: CE-940: CE-941	Lamina 5	Fagor Industrial S.Coop. FAGOR
					Ofoto

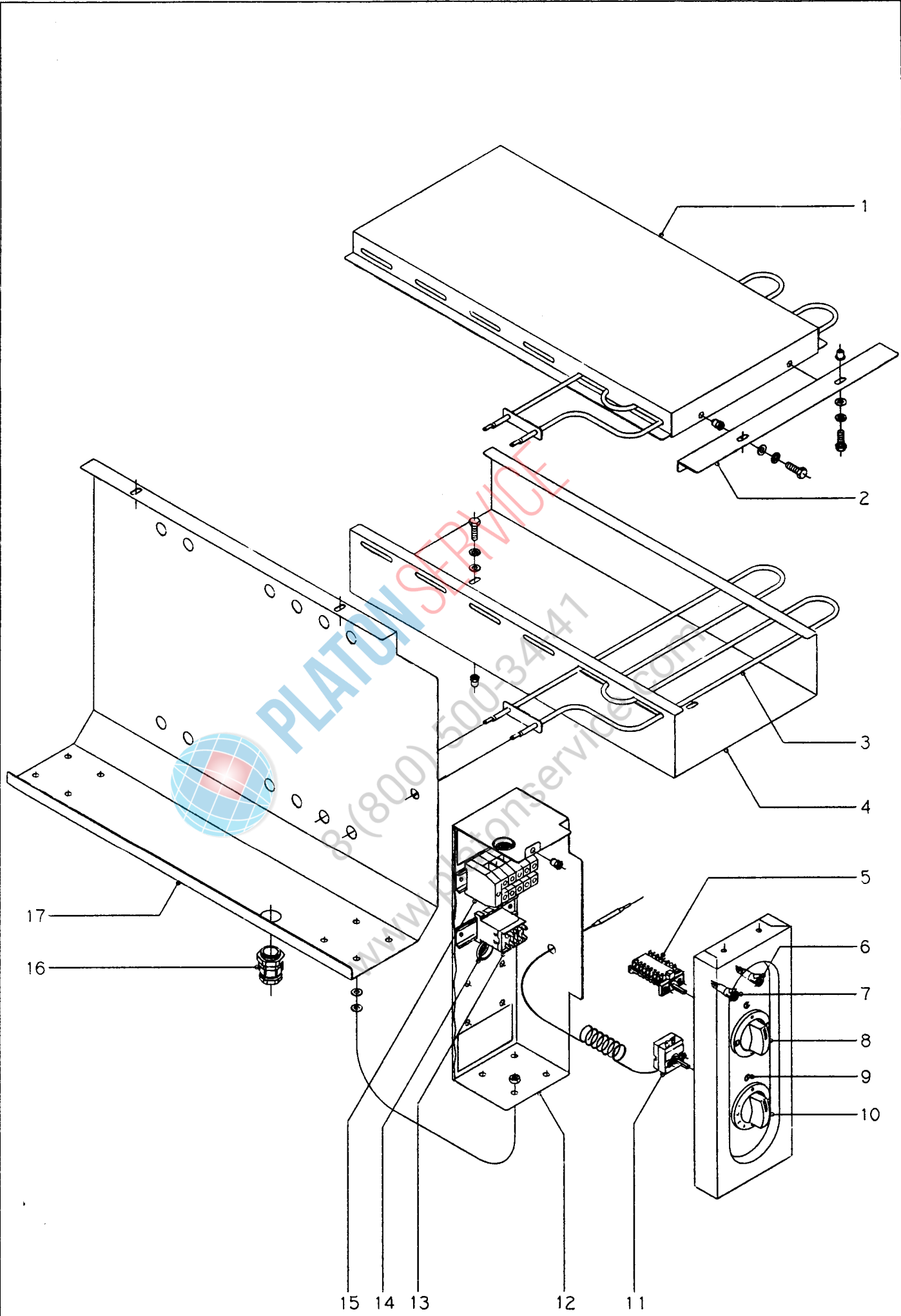

N plano C-302	Firma 	Fecha X-95	Aparato COCINA CE-941	Lamina 6	Fagor Industrial S.Coop. FAGOR
------------------	-----------	---------------	--------------------------	-------------	---------------------------------------

CONCEPTO: PARTE FUNCIONAL ELECTRICA HORNO SUJET: PIECES ELECTRIQUES DU FOUR CONCEPT: OVEN ELECTRICAL PARTS					LAMINAN° VUE N° 6 ILUSTR. N.		PLANON° PLAN N° C-302 DRAWINGN.		PAGINAN° PAGEN° 19 PAGEN.	
APARATO - APPAREIL - APPLIANCE: Cocinas - Fourneaux - Ranges					MODELO Y CANTIDAD - MOD. ET QUANT. - MOD. & QUANT.					OBSERVACIONES
N°	CODIGO	DENOMINACION	DENOMINATION	DESCRIPTION	CE-941					
1	U672606	Soporte superior resistencias	Support supérieur resistances	Upper heating-element support	1					
	Q221343	Remache exagonal M.6	Rivet M.6	Rivet M.6	2					
	Q302022	Arandela plana 16x6x1,2	Rondelle 16x6x1,2	Washer 16x6x1,2	2					
	Q262040	Arandela muelle A.6	Rondelle A.6	Washer A.6	2					
	Q012042	Tornillo exagonal M.6x15	Vis M.6x15	Bolt M.6x15	2					
2	U672607	Escuadra amarre soporte	Equerre fixation support	Fastening plate	1					
	Q221304	Remache redondo M.5	Rivet M.5	Rivet M.5	2					
	Q302022	Arandela plana 16x6x1,2	Rondelle 16x6x1,2	Washer 16x6x1,2	2					
	Q261030	Arandela muelle A.5	Rondelle A.5	Washer A.5	2					
	Q012031	Tornillo exagonal M.5x10	Vis M.5x10	Bolt M.5x10	2					
3	U183030	Resistencia 1000 W. 230 V.	Resistance 1000 W. 230 V.	Heating element 1000 W. 230 V.	6					
3	U188101	Resistencia 1000 W. 440 V.	Resistance 1000 W. 440 V.	Heating element 1000 W. 440 V.	6					
4	U672603	Soporte inferior resistencias	Support inférieur resistances	Lower heating-element support	1					
	Q221342	Remache exagonal M.5	Rivet M.5	Rivet M.5	2					
	Q302022	Arandela plana 16x6x1,2	Rondelle 16x6x1,2	Washer 16x6x1,2	2					
	Q261030	Arandela muelle A.5	Rondelle A.5	Washer A.5	2					
	Q012032	Tornillo exagonal M.5x15	Vis M.5x15	Bolt M.5x15	2					
5	U673006	Conmutador	Conmutateur	Switch	1					
	Q151320	Tornillo alomado M.4x6	Vis M.4x6	Bolt M.4x6	2					
6	Z203005	Piloto ámbar	Témoin jaune	Yellow light	1					
7	Z203004	Piloto verde	Témoin vert	Green light	1					
8	U673004	Botón de mando 6	Bouton de commande 6	Control button 6	1					
9	U562806	Indicador posición "O"	Indicateur position "O"	"Off" indicator	2					
	Q221026	Clip sujeción indicador	Clip fixation	Fastening clip	2					
10	U673005	Botón de mando 6	Bouton de commande 6	Control button 6	1					
11	X153000	Termostato 50-310 °C	Thermostat 50-310 °C	Thermostat 50-310 °C	1					
	Q151320	Tornillo alomado M.4x6	Vis M.4x6	Bolt M.4x6	2					
12	U673000	Cuadro eléctrico	Boîte électrique	Electrical box	1					
	Q221343	Remache exagonal M.6	Rivet M.6	Rivet M.6	1					(Amarre superior)
	Q302022	Arandela plana 16x6x1,2	Rondelle 16x6x1,2	Washer 16x6x1,2	4					(Entre protección salpicadura y remache)
	Q162040	Tuerca exagonal M.6	Ecrou M.6	Nut M.6	2					(Amarre inferior)

CONCEPTO: PARTE FUNCIONAL ELECTRICA HORNO					LAMINAN°	PLANON°	PAGINAN°		
SUJET: PIECES ELECTRIQUES DU FOUR					VUE N° 6	PLAN N° C-302	PAGEN°		
CONCEPT: OVEN ELECTRICAL PARTS					ILUSTR. N.	DRAWING N.	PAGEN. 20		
APARATO - APPAREIL - APPLIANCE: Cocinas - Fourneaux - Ranges					MODELO Y CANTIDAD - MOD. ET QUANT. - MOD. & QUANT.				OBSERVACIONES
N°	CODIGO	DENOMINACION	DENOMINATION	DESCRIPTION	CE-941				
13	Z213007	Contactador 230 V. 50/60 Hz.	Contacteur 230 V. 50/60 Hz.	Switch 230 V. 50/60 Hz.	1				
	R663055	Guía contactor 120	Guide de contacteur	Switch support	1				
	Q419005	Remache tubular 4x8	Rivet 4x8	Rivet 4x8	2				
14	X723014	Pasamuros	Protection de cablage	Wire protection	2				
15	R263003	Borna gris paso	Prise gris (phase)	Wire block grey (phase)	3				
	R673010	Borna azul neutro	Prise bleu (neutre)	Wire block blue(neutral)	1				
	Z103035	Borna amarillo-verde tierra	Prise jaune-vert (terre)	Wire block yellow-green (earth)	1				
	Z683096	Tope final	Butoir	Stop	1				
	R663055	Guía contactor 120	Guide de contacteur	Switch support	1				
	Q419005	Remache tubular 4x8	Rivet 4x8	Rivet 4x8	2				
16	R023013	Prensaestopas	Passe-cable	Wire protection	1				
17	U672601	Chapa protección salpicaduras	Plaque protection	Protection plate	1				

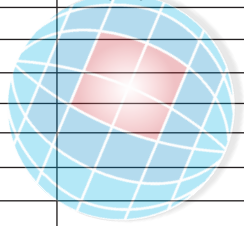

8 (800) 500-3447
www.platonservice.com

CONCEPTO: VARIOS					LAMINANº			PLANONº			PAGINANº	
SUJET: AUTRES PIECES					VUE Nº			PLAN Nº			PAGENº	
CONCEPT: VARIOUS					ILUSTR. N.			DRAWINGN.			PAGEN.	
APARATO - APPAREIL - APPLIANCE: Cocinas - Fourneaux - Ranges					MODELO Y CANTIDAD - MOD. ET QUANT. - MOD. & QUANT.						OBSERVACIONES	
Nº	CODIGO	DENOMINACION	DENOMINATION	DESCRIPTION	CE-920	CE-940	CE-941					
	Z206101	Placa matrícula	Plaque caractéristiques	Features plate	1	1	1					
	U676500	Folleto de instrucciones	Livret d'instructions	Instructions brochure	1	1	1					
	U653001	Esquema eléctrico adhesivo	Schema électrique	Electrical schema	1	-	-					
	U663000	Esquema eléctrico adhesivo	Schema électrique	Electrical schema	-	1	-					
	U673001	Esquema eléctrico adhesivo	Schema électrique	Electrical schema	-	-	1					



CONCEPTO: PIEZAS ESPECIFICAS PARA LOS DISTINTOS VOLTAJES SUJET: PIECES ELECTRIQUES SPECIFIQUES CONCEPT: SPECIAL ELECTRICAL PARTS					LAMINAN° VUEN° 5 y 6 ILUSTR. N.			PLANON° PLAN N° DRAWINGN.			PAGINAN° PAGEN° 22 PAGEN.	
APARATO - APPAREIL - APPLIANCE: Cocinas - Fourneaux - Ranges					MODELO Y CANTIDAD - MOD. ET QUANT. - MOD. & QUANT.					OBSERVACIONES		
N°	CODIGO	DENOMINACION	DENOMINATION	DESCRIPTION	CE-920	CE-940	CE-941					
VERSION 220/240/380/415 V; 50/60 Hz. (CON NEUTRO)												
1	U673011	Placa 3000 W. 230 V.	Plaque 3000 W. 230 V.	Plate 3000 W. 230 V.	1	3	3				(lámina 5)	
1	U673010	Placa 4000 W. 230 V.	Plaque 4000 W. 230 V.	Plate 4000 W. 230 V.	1	1	1				(lámina 5)	
5	Z203005	Piloto ámbar 230 V.	Témoin jaune 230 V.	Yellow light 230 V.	2	4	4				(lámina 5)	
3	U183030	Resistencia horno 1000 W 230 V	Resistance four 1000 W. 230 V.	Heating element 1000 W. 230 V.	-	-	6				(lámina 6)	
6	Z203005	Piloto ámbar 230 V.	Témoin jaune 230 V.	Yellow light 230 V.	-	-	1				(lámina 6)	
7	Z203004	Piloto verde 230 V.	Témoin vert 230 V.	Green light 230 V.	-	-	1				(lámina 6)	
s/n	P306506	Indicador de tensión (220 V.)	Indicateur (220 V.)	Indicator (220 V.)	1	1	1					
s/n	X703303	Indicador de tensión (240 V.)	Indicateur (240 V.)	Indicator (240 V.)	1	1	1					
s/n	U673502	Indicador de tensión (380/415 V)	Indicateur (380/415 V.)	Indicator (380/415 V.)	1	1	1					
VERSION 380/415/440 V; 50/60 Hz. (SIN NEUTRO)												
1	U673012	Placa 3000 W. 400 V.	Plaque 3000 W. 400 V.	Plate 3000 W. 400 V.	1	3	3				(lámina 5)	
1	U673013	Placa 4000 W. 400 V.	Plaque 4000 W. 400 V.	Plate 4000 W. 400 V.	1	1	1				(lámina 5)	
5	U673016	Piloto ámbar 400 V.	Témoin jaune 400 V.	Yellow light 400 V.	2	4	4				(lámina 5)	
3	U183030	Resistencia horno 1000 W 230 V	Resistance four 1000 W. 230 V.	Heating element 1000 W. 230 V.	-	-	6				(lámina 6)	
6	Z203005	Piloto ámbar 230 V.	Témoin jaune 230 V.	Yellow light 230 V.	-	-	1				(lámina 6)	
7	Z203004	Piloto verde 230 V.	Témoin vert 230 V.	Green light 230 V.	-	-	1				(lámina 6)	
s/n	U673018	Transformador 400/230 V.	Transformateur 400/230 V.	Transformer 400/230 V.	-	-	1					
s/n	U673017	Cableado transformador	Cablage	Wire	-	-	1					
s/n	U673502	Indicador de tensión (380/415 V.)	Indicateur (380/415 V.)	Indicator (380/415 V.)	1	1	1					
s/n	P358103	Indicador de tensión (440 V.)	Indicateur (440 V.)	Indicator (440 V.)	1	1	1					

1.5.- Esquema eléctrico.

CE-920

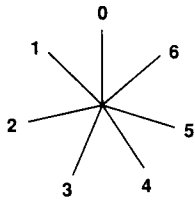

POS.	P1		P2		P3
	1	2	3	4	5
0					
1	X			X	X
2			X	X	X
3		X		X	X
4	X		X		X
5		X	X	X	X
6	X	X	X	X	X

- r = rojo
- m = marrón
- g = gris
- n = negro
- a = azul
- b = blanco
- ve = verde
- am/ve = amarillo/verde

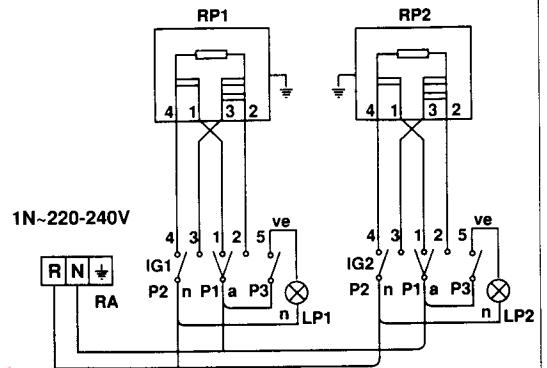

CE-940

- RA: Regleta de Alimentación
- IG1, IG2: Conmutadores de placas eléctricas
- RP1, RP2: Placas eléctricas
- LP1, LP2: Lámpara Calentamiento de Placas

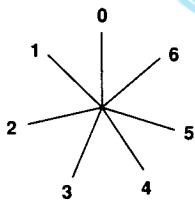

POS.	P1		P2		P3
	1	2	3	4	5
0					
1	X			X	X
2			X	X	X
3		X		X	X
4	X		X		X
5		X	X	X	X
6	X	X	X	X	X

- r = rojo
- m = marrón
- g = gris
- n = negro
- a = azul
- b = blanco
- ve = verde
- am/ve = amarillo/verde

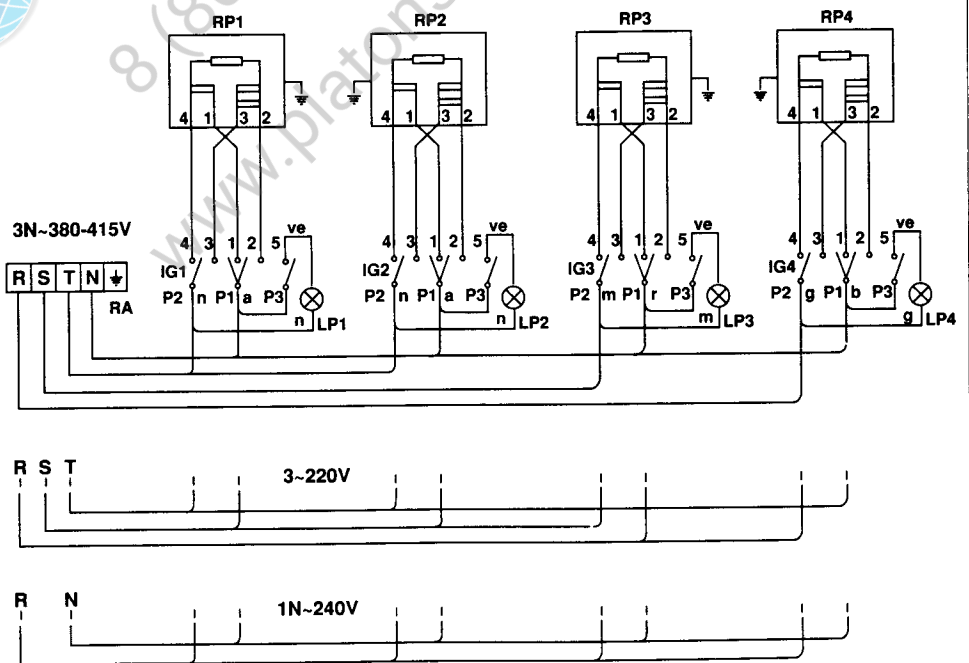

CE-941

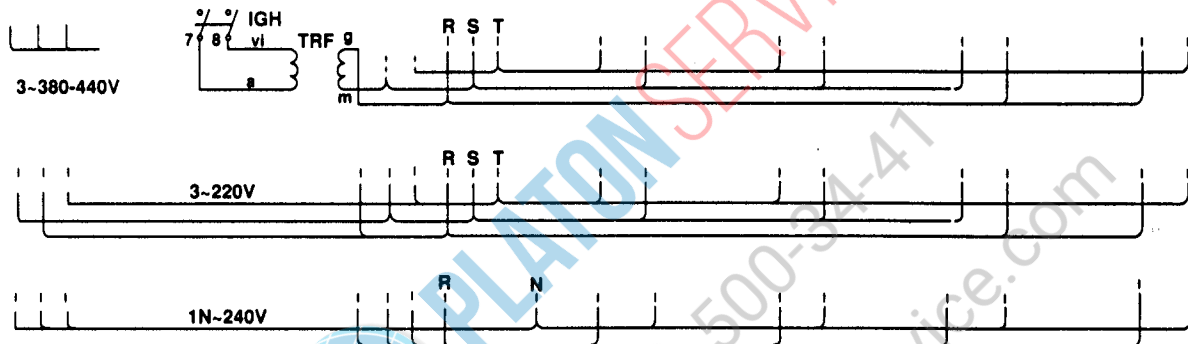
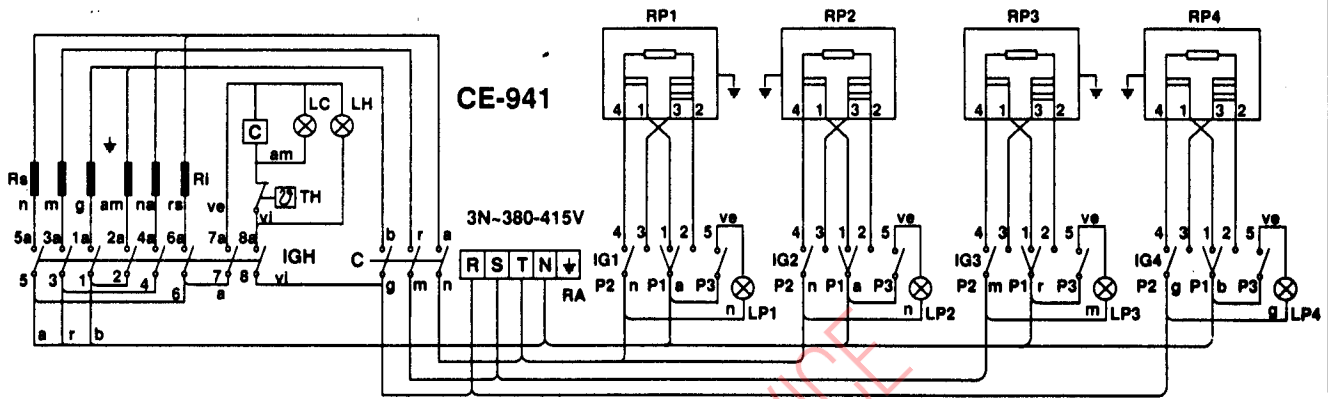

	1-2	3-4	5-6	7	8			
	1a	2a	3a	4a	5a	6a	7a	8a
0								
1	X		X	X	X	X	X	
2	X	X	X	X	X	X	X	
3		X	X		X	X	X	

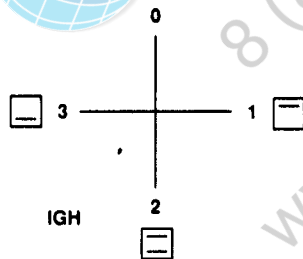

- r = rojo
- m = marrón
- g = gris
- n = negro
- a = azul
- b = blanco
- vi = violeta
- am = amarillo
- na = naranja
- rs = rosa
- ve = verde
- am/ve = amarillo/verde

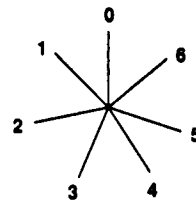

	P1			P2		P3
POS.	1	2	3	4	5	
0						
1	X			X	X	
2		X		X	X	
3	X			X	X	
4	X		X	X	X	
5	X	X	X	X	X	
6	X	X	X	X	X	

1.6.- Transformaciones a las diversas tensiones.

Para realizar un cambio de tensión sobre la instalación original del aparato basta con adecuar la regleta de entrada según el esquema eléctrico que corresponda a la tensión deseada. El acceso a la regleta se realiza soltando el panel inferior y portamandos lateral mediante los tornillos situados en la parte inferior de los mismos.

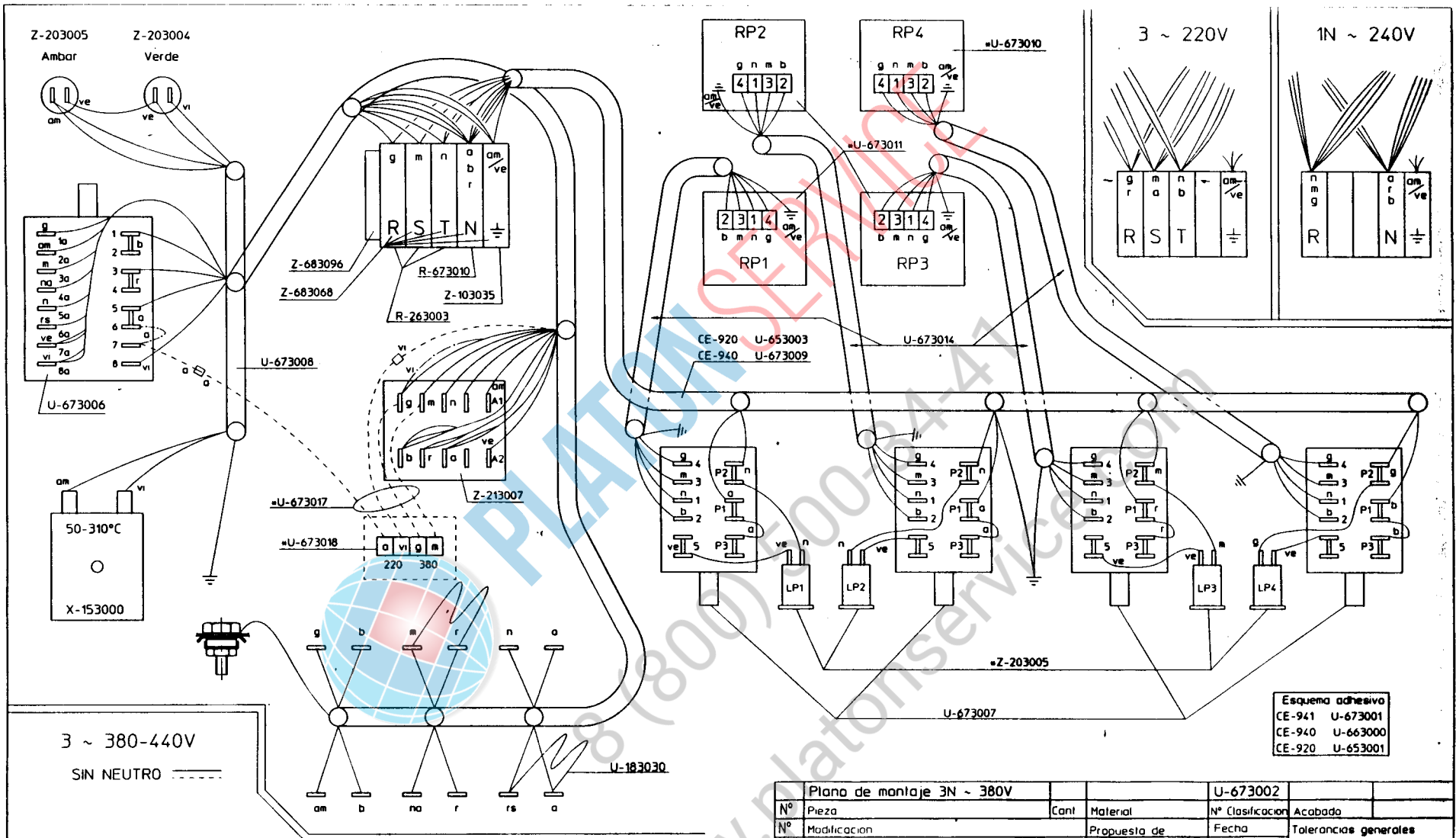

----- Versión sin Neutro

- * Inst. Auxil. : U-673017
- * TRANSFORMADOR : U-673018
- * RP1, RP2, RP3 : U-673012
- * * RP4 : U-673013
- * LP1, LP2, LP3, LP4 : U-673014

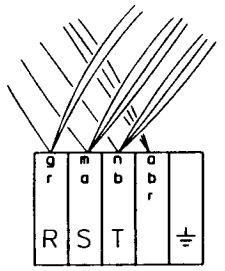

Esquema adhesivo
 CE-941 U-673001
 CE-940 U-663000
 CE-920 U-653001

Plano de montaje 3N ~ 380V		U-673002				
Nº	Pieza	Cont	Material	Nº Clasificación	Acabado	
Nº	Modificación	Propuesta de		Fecha	Tolerancias generales	
					< 5 :	50-100:
					5-75:	> 100:
					75-50:	OX :
Dibujado	Firma	Fecha			Mecanzado superficial	
Proyectado	JON	95-9-13				
Comprobado	<i>Lehug</i>					
Escala						
COCINAS					Plano número	
Plano hau ez dafete erabil ez berritza gure baimeniz gabe					HC-71191	
					Sustituye al N°	
					Sustituido por	